

APANET

GREEN SYSTEM



SMART STREET LIGHT CONTROLLER

GLC100 SERIES

USER MANUAL

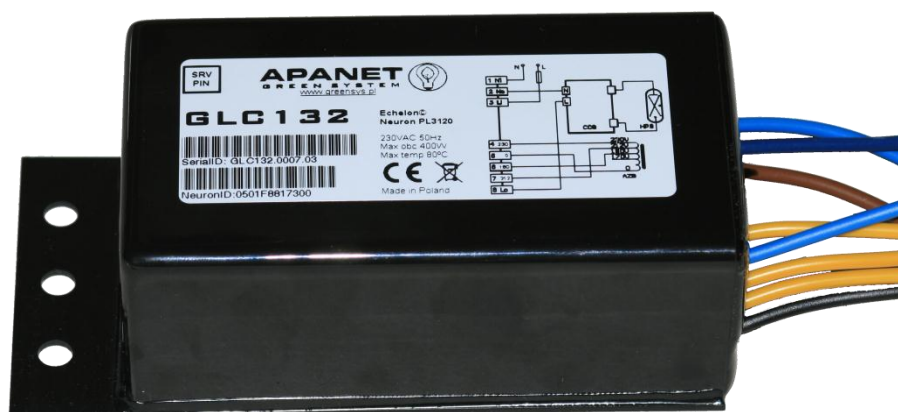

VERSION 2.2

APANET GREEN SYSTEM SP. Z O.O.
SW. ANTONIEGO 2/4 50-073 WROCLAW POLAND

EN.GREENSYS.PL

Table of contents

1	Introduction	3
2	Hardware.....	4
2.1	Electrical and mechanical parameters	4
2.2	Communication	4
2.3	Service Pin	5
2.4	Measurements	5
2.5	Controlling.....	5
2.6	Wiring diagrams	6
2.6.1	Power reduction using an electromagnetic ballast	6
2.6.2	Power reduction using an autotransformer	6
2.6.3	Power reduction using an electronic ballast (1-10V).....	7
2.7	Dimension.....	7
2.8	Ordering information	8
3	Software.....	8
3.1	LonMark© object	8
3.1.1	Outdoor Luminaire Controller	8
3.1.2	Node Object	9
3.1.3	Reactive energy.....	9
3.1.4	Reactive power	9
3.1.5	THD (total harmonic distortion).....	9
3.1.6	Lamp guard (fail controller)	9
3.2	Network variables	9
3.3	Configuration properties.....	10

1 Introduction

The GLC100 controller is intended to manage a single light source (light socket) operating within outdoor lighting (i.e. street, car park or park lighting) control systems. The controller utilizes LonWorks communication standard over power lines (PowerLine communication) helping significantly reduce installation costs.

The controller enables full control of a light source – managing light intensity, power usage metering, diagnosing and reporting occurrences and malfunctions. This in turn enables implementation of algorithms to significantly reduce power usage (cost and CO2 emission reduction) and reduce servicing costs.

The controller utilizes advanced network information flow control technology (routing) – this means that each device can work as a repeater – which enables constructing of wide area control networks (up to 4km range in standard power grid). Additionally communication is configured dynamically, adopting to the network parameters changes.

Different controller models enable implementation in various applications – together with electronic ballast working in 1-10V and Dali standards and ballast with power reduction function.

The controller features a very powerful measurement module (energy and power active and reactive, power factor, THD) for managing the power grid.

LonWorks standard communication and LonMark compatibility give full flexibility in constructing networks and possibility of using components from various providers – both, for the low level devices and even SCADA supervising and control systems. It also enables an easy integration with currently implemented systems.

APANET offers dedicated supervising and control system characterized by a unique scalability attribute relating to software and hardware, from the street level to entire city.

Main advantages:

- ✓ Works with electronic and electromagnetic ballasts.
- ✓ Gradual (0-100%) and discrete (two levels) light dimming.
- ✓ Ability to control each light source independently.
- ✓ Ability to monitor each light power consumption independently.
- ✓ Powerful measurement module (energy and power active and reactive, power factor, THD).
- ✓ Monitoring lamp status (malfunction detection and reporting) – lower servicing cost.

- ✓ Flexible and decentralized network structure – better functionality and reliability.
- ✓ Advanced routing algorithms – wide network range.
- ✓ Low installation costs – communication using 230VAC electrical network.
- ✓ Installation in a lamp socket or a lamp post.
- ✓ Over the network software upgrade.
- ✓ LonWorks compatibility.
- ✓ LonMark compatibility.

2 Hardware

2.1 Electrical and mechanical parameters

- Supply:..... 230VAC
- Maximal load:..... 400W
- Temperature range -40°C to 80°C
- Wight:..... 600g
- Dimension (without mounting)..... 115x65x43mm
- Dimension (with mounting) 135x65x43mm
- Connection: 1,5mm² wires
- Housing..... IP67

2.2 Communication

GLC100 series controllers communicate with master systems utilizing LonWorks communication standard, which uses power lines (PowerLine communication) according to CELELEC specification band C. More detailed information regarding LonWorks networks can be found at Echelon web site www.echelon.com.

2.3 Service Pin

A GLC100 series controller uses standard identification number routing mechanism - a service message generated after pushing a service pin. To ensure a device is fully sealed a reed relay placed in the top left corner of a device is being used. In order to transmit a service message through the network a small magnet needs to be applied at the marked point.

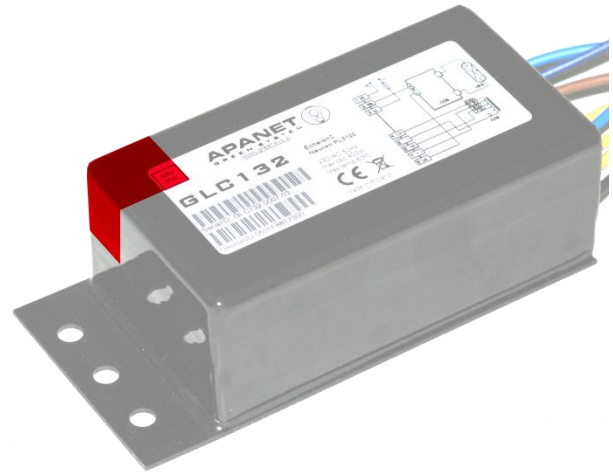

2.4 Measurements

A GLC100 series controller can be equipped with one of the measurement modules:

- Energy and active power readings (GLC1x1 versions)
- Active and reactive energy and power readings, RMS values of voltage and current measurement, power factor and THD measurement (GLC1x2 versions).

There is also a controller model without a measurement module available.

2.5 Controlling

A GLC100 series controller can be equipped in one of the following control modules:

- Dual-state control (ON / OFF) - enables street lamp remote control (GLC10x versions).
- Tri-state control (one level of power reduction) - enables implementation of energy saving algorithms based on a street lamp power reduction (GLC11x versions). The solution is dedicated to electromagnetic ballasts.
- Four-state control (two levels of power reduction) - enables implementation of advanced energy saving algorithms based on a street lamp power reduction (GLC13x versions). The solution is dedicated to electromagnetic ballasts with an autotransformer.
- Continues control (analog output) – enables precise power control of a light source (GLC12x versions). The solution dedicated to electronic ballasts with analogue input operating in 1-10V standard.

2.6 Wiring diagrams

2.6.1 Power reduction using an electromagnetic ballast

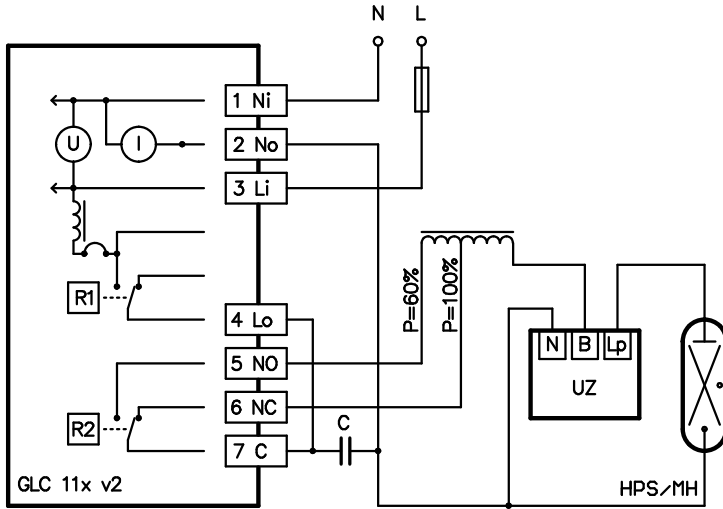

2.6.2 Power reduction using an autotransformer

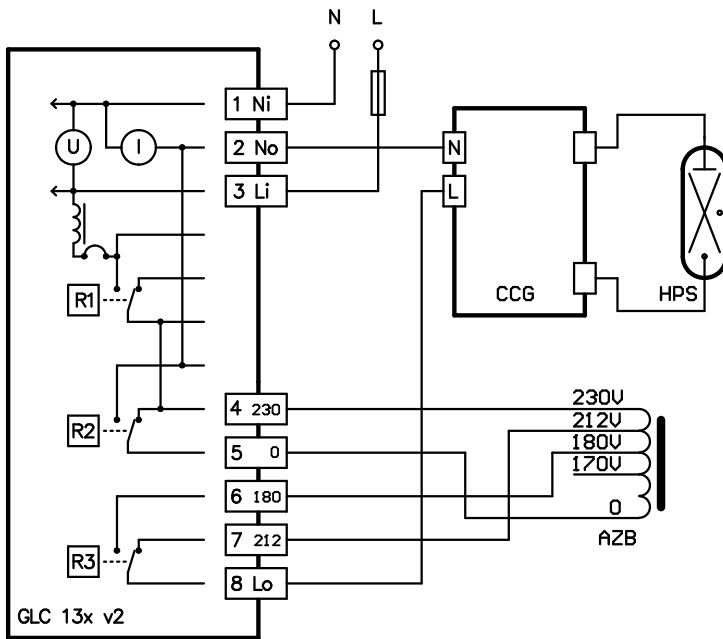

2.6.3 Power reduction using an electronic ballast (1-10V)

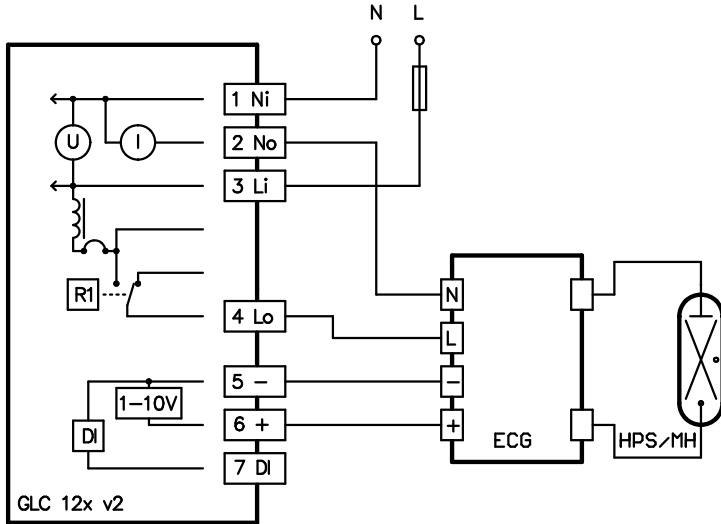

2.7 Dimension

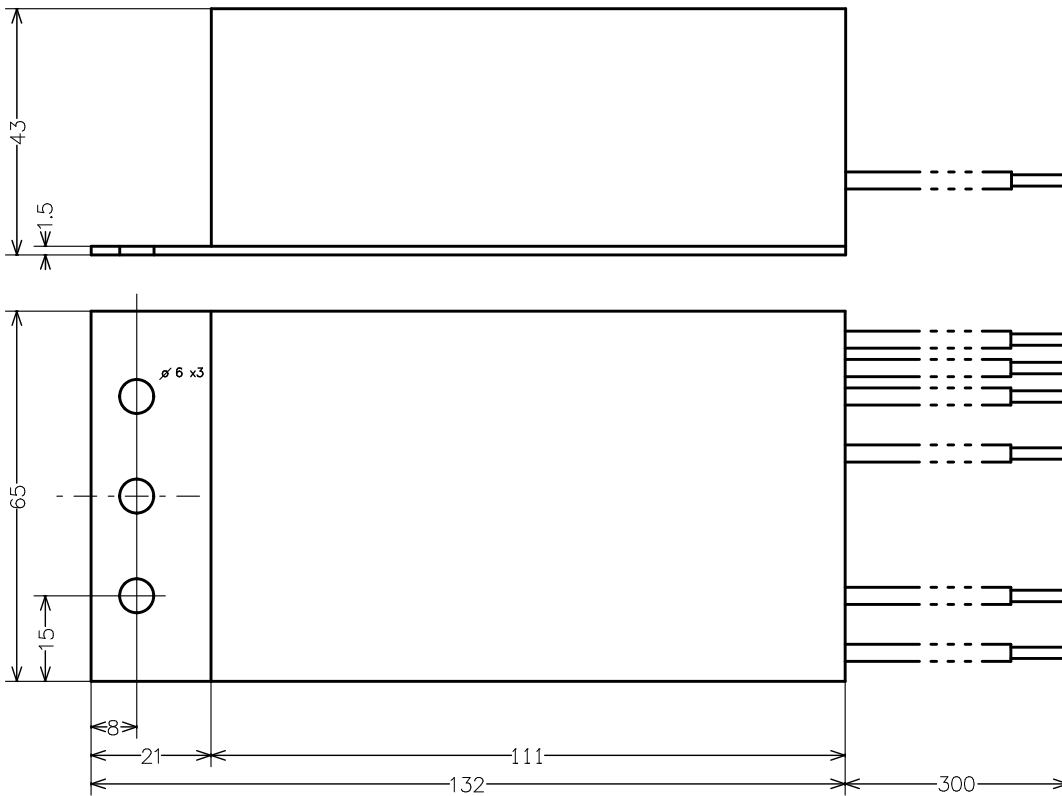

2.8 Ordering information

GLC1 X Y

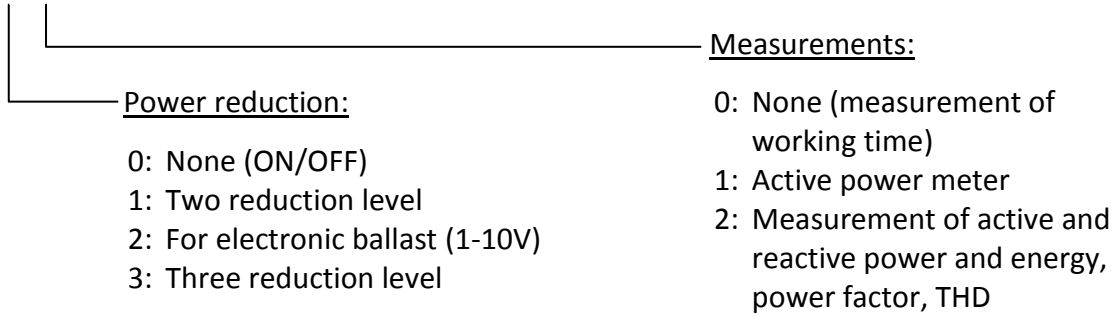

3 Software

3.1 LonMark® object

GLC100 series controller firmware is compatible with LonMark standard. It allows for an easy integration with existing systems and other manufacturer's devices and simplifies device configuration. More information about the standard can be found at company's web site: www.lonmark.org. The controller utilises a "Standard Functional Profile Template - SFPT" - "Lamp Actuator" (number 3040).

3.1.1 Outdoor Luminaire Controller

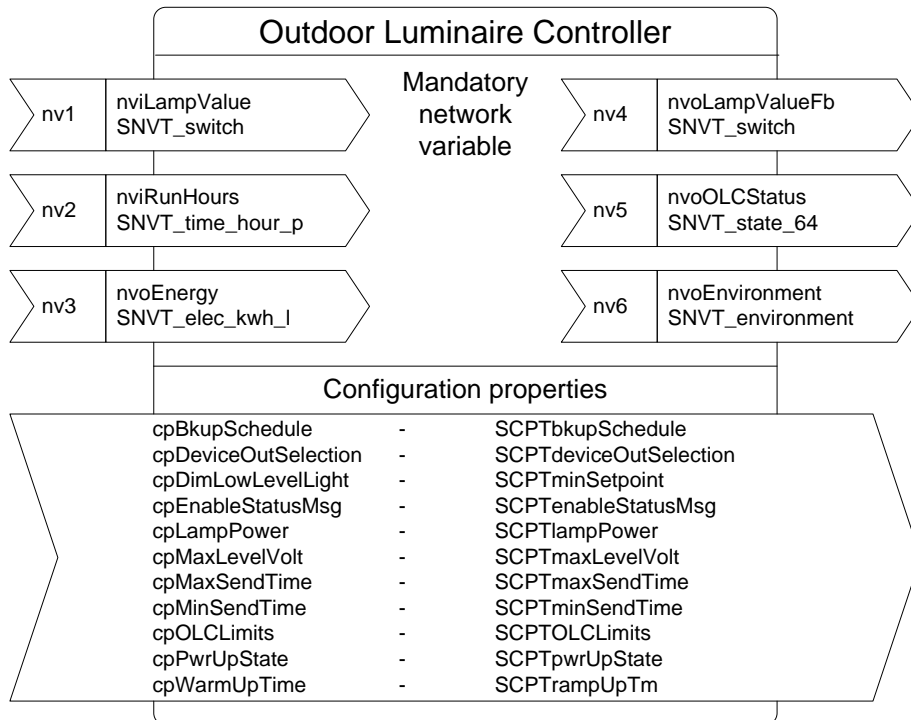

3.1.2 Node Object

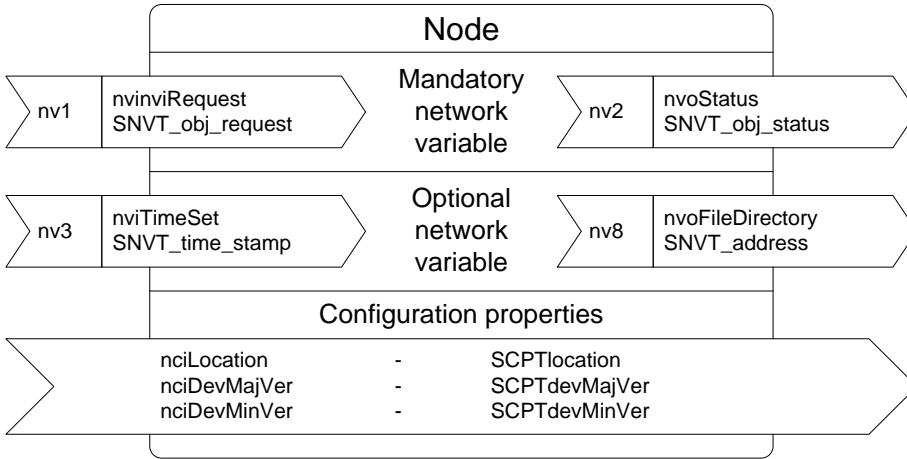

3.1.3 Reactive energy

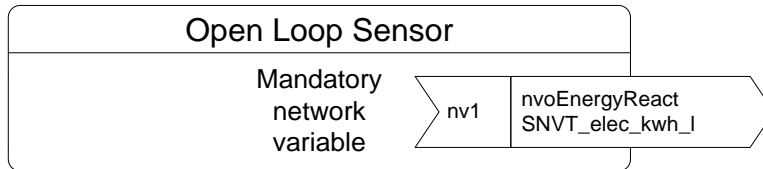

3.1.4 Reactive power

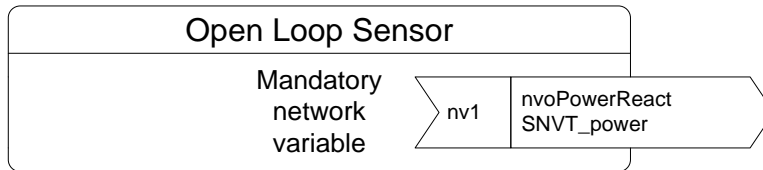

3.1.5 THD (total harmonic distortion)

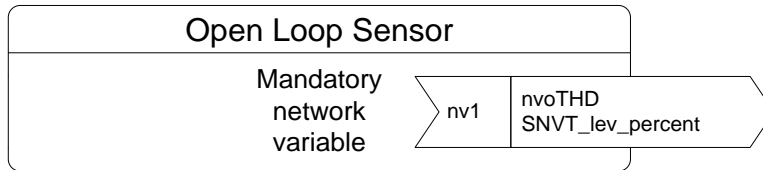

3.1.6 Lamp guard (fail controller)

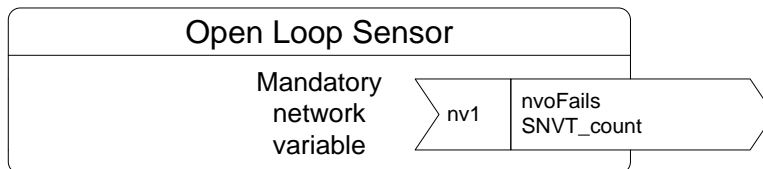

3.2 Network variables

The LonWorks standard uses network variables to exchange information between system elements. In order to guarantee compatibility with other LonMark systems a GLC100 series controller uses standard network variables - "Standard Network Variable Types – SNVT".

3.3 Configuration properties

The LonWorks© standard uses configuration properties to configure devices. In order to guarantee compatibility with other LonMark systems a GLC100 series controller uses standard configuration properties - "Standard Configuration Property Types - SCPT".